

Bulletin No. **Split-021**

Supersedes: (None)

SUBJECT: New Model Introduction in Split 1.0 TR Category.

Purpose: -

This bulletin is to introduce Octra (5 Star) with 12K IDU Chassis in 1.0TR category of Split Air Conditioners. The new model will have Installation Kit Inside the ODU.

Appearance: -

1.0 TR Octra IDU



CDU-W110 Chassis (1.0 TR)



Engineering Approval: B. Phani Kanth

Prepared By: Ankush Mehta

Model Details: -

12K Octra (5 Star)			
Model	IDU Code	ODU Code	Product Code
12K Octra (5 Star)	224050031460	224050032380	224050031470

Technical Specification:

Condensing and Indoor Unit Specifications				
MODEL		12K Octra 5 Star (42KGN-012Sm + 38MSN-012SS)		
Function		Cooling		
Power Supply		230V-1ph-50 Hz		
		Btu/h	12200	
Electrical Data			Indoor Unit	Outdoor Unit
	Running Current	A	0.3	5.0
	Power Input	W	43	940
Compressor	Type	Rotary		
	Model	PH190M2A-4FTL1		
	Capacitor (MFD)	35		
		Unit		
Fan	Type	Indoor Unit	Outdoor Unit	
	RPM(Hi//Med/Lo)	1050/900/800	900	
	Fan Motor (Speed)	4 Speed	1 Speed	
	Motor Model No.	RPG20D(Welling)	YDK36-6	
Connection	Type	Flare		
	OD(Liquid/Suction)	1/4" , 1/2"		
Refrigerant (R-22)	Control	Capillary		
	Charge (g)	1120		
Gross Dimension (W*H*D)		mm	835 X 330 X 265	910 X 585 X 335
Net. Weight		kg	7	29.5

Net Dimensions of 12K Superia :

MODEL	Dimensions(W*D*H)
IDU	770x188x255
ODU	780x250x540

BEE Label:-

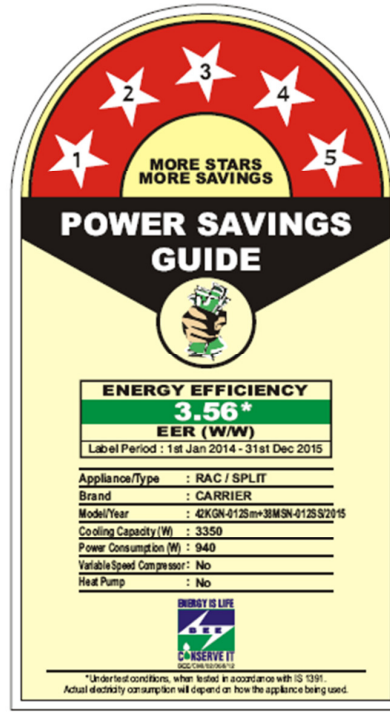

Electrical Wiring Diagram of IDU :-

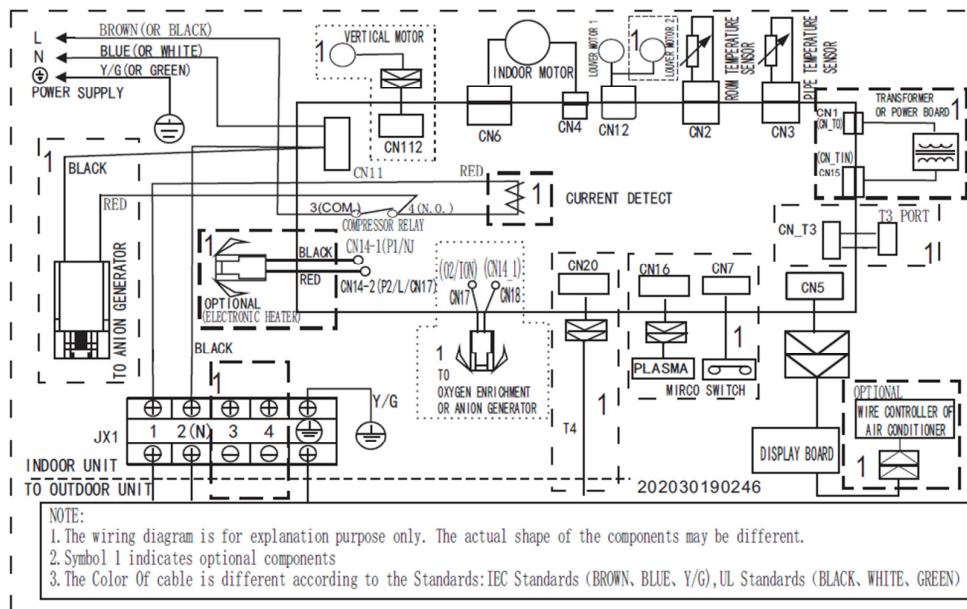

Electrical Wiring Diagram of ODU: -

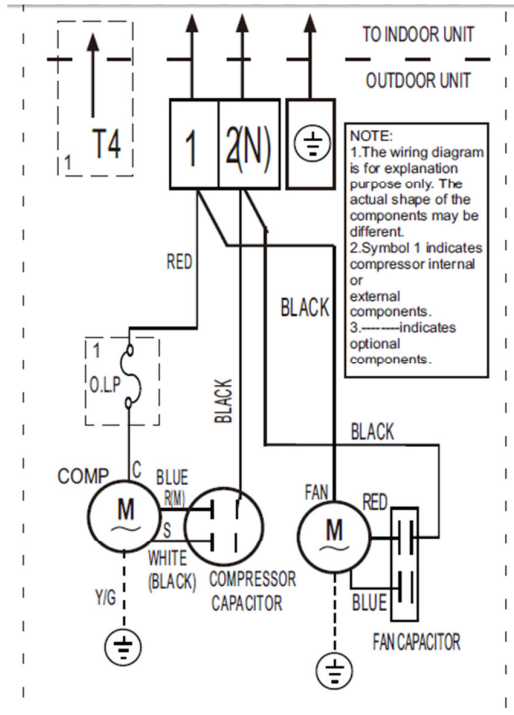

Installation Kit Inside ODU: -





Transparent Sticker mentioning
"Installation Kit Inside"

